

Propane Specialist Response Kit

Tank/Cyl Connection Quick Reference Guide



Responder Training Enterprises, LLC
P.O Box 182
Shirley, Indiana 47384
(765) 524-4848
respondertraining.rdh@gmail.com

03/10/2024
Version 1.3

U
S
E
R
S

G
U
I
D
E



INDEX

Page	Description
3	QR links to operational videos
4	Kit Component Location Sheet Page 1
5	Kit Component Location Sheet Page 2
6	Quick I.D. Sheet and Component Locator
7	Residential Tanks
8	Underground Tanks
9	Small Cylinder/OPD Valves
10	Motor Fuel Tanks
11	Specialty Tank Connectors
12	Bulk Plants and DOT MC330/331
13	OPD with QCC Type 1 and POL Valve
14	Liquid Withdrawal Valve Spec Sheet
15	Specialty Liquid Withdrawal Adapters
16	Fill Valves and Unloading Adapters
18	Basic Propane Metering System Components
18	Propane Fact Sheet
19	Flaring Site Plan (training/incident)

Pages 13, 14, 15, and 18 are handouts that I created for our class titled “Propane Response – 101 to Advanced Tactics”. I added them in this Users Guide to aid you on scene.

If you are ever on scene and would like another perspective feel free to call me. If I can, I'll take the call or I'll call you back as soon as possible.

Ronald (Ron) Huffman
(765) 524-4848

Propane Specialist Response Kit

component location and application Guide

As responders ourselves, we understand that your team members have a lot to remember. This document has been designed using images and numbers assigned to the Propane Specialist Response Kits components to assist in quickly identifying what is needed to connect to what you're working on.

To augment this users Guide I will be creating short videos to assist the first responders that can be viewed on scene. The QR code below will take you to a page on our website where you can select and view videos related to what you're working on.

Scan this QR link to access the Propane Specialist Response Kit's Users Guide Video Link Page



<https://www.respondertraining.com/psrk-users-guide-video-links/>



Propane Specialist Response Kit



ResponderTraining.com

NOTE

This users guide and associated online videos do not provide guidance or information for every component of the **Propane Specialist Response Kit** or training. It is intended to augment training provided by **Responder Training Enterprises, LLC**.

Propane Specialist Response Kit Users Guide

Kit Component Location Index

Kit Item Identifier	Description	Located in Box #
1	1-3/4" Female ACME Vapor Adaptor X 1-3/4" Male ACME	1
2	1-3/4" Female ACME X 1-3/4" Male ACME 90 degree	1
3	3-1/4" Female X 1-3/4" Male ACME	1
4	1-1/4" Female ACME Vapor Adaptor X 1-3/4" Male ACME	1
5	1-5/16" QCC/OPD tank EVACUATION ADAPTER (no Excess Flow Valve)	1
6	Full Flow P.O.L. X 1-3/4" Male ACME	1
7	Reserve Cylinder Adapter Female POL	1
8	2-1/4" Female X 1-3/4" Male ACME	1
9	Fork Truck Safety Connector X 1-3/4" Male ACME	1
10	Bottle, high pressure pipe sealant	1
11	Box #1 foam insert	1
12	Propane Specialist Response Kit Box # 1	1
13	1-3/4" Male ACME x 1/4" Female NPT	1
14	1-3/4" Male ACME x 3/4" Female NPT	1
15	1-3/4" Cap	1
16	Reserved	1
17	Flomatic internal valve manual activation tool	1
18	1/4" ball valve	1
19	1-1/4" Cap	1
20	Bleeder plug	1
21	2 - 3/16" MC-331 internal valve handle pin (cotter pin)	1
22	2 - 1/8" MC-331 internal valve handle pin (cotter pin)	1
23	2 - 1/16" MC-331 internal valve handle pin (cotter pin)	1
24	1-1/4" ACME Propane Vapor Gasket	1
25	1-3/4" ACME Propane Filler Valve Gasket	1
26	2-1/4" ACME Propane Filler Valve Gasket	1
27	3-1/4" ACME Propane Filler Valve Gasket	1
28	Liquid Unloading Adapter Nylon Gasket	1
29	Liquid Unloading Adapter O-Ring	1
30	1/2-inch roll of high-pressure Teflon tape	1
31	300 psi bottom mount pressure gauge	1
32	Liquid Unloading Valve Assembly (new style) straight	2
33	1-inch pressure gauge assembly (300psi)	2
34	3121 Unloading Adapter	2
35	Liquid Unloading Valve Assembly (new style) 90 degree	2
36	Liquid Unloading Valve Assembly (old style) 90 degree	2
37	Hard Nose POL Plug	2
38	Fill Valve Adapter (Check Valve)	2
39	1-3/4" Female ACME X 1-3/4" Male ACME Unloading Adapter	2
40	1-3/4" Male ACME X 1-3/4" Male ACME	2
41	Box #2 foam insert	2

Kit Item Identifier	Description	Located in Box #
42	Propane Specialist Response Kit Box # 2	2
43	Gloves 1-pair	3
44	Gloves 1-pair	3
45	Wood Plug Kit	3
46	1-3/4" Female ACME X 1-3/4" Female ACME	3
47	Tool Tote	3
48	OPTIONAL - Emergency ESV W/manual Latch and 30-foot stainless steel cable and pull handle	3
49	3-1/4" Male ACME x 3-1/4" Male ACME	3
50	1-inch 3-way valve	3
51	Bottle, Leak Check Fluid	3
52	Liquid loading/unloading tank valve w/ball valve and 1-3/4" male ACME	3
53	High Pressure (250 psi) 1/4" quick connect x Female POL	3
54	Mower Propane Tank Connector (left hand thread) x Female POL	3
55	CGA 555 x Female POL	3
56	3/8" Male Quick Connector x Female POL	3
57	Low Pressure 1/4" quick connect x Female POL	3
58	7580F liquid loading unloading tank valve w/ball valve and 1-3/4" male ACME	3
59	Propane Specialist Response Kit Box # 3	3
60	Box #3 foam insert	3
61	Extra Heavy Couplings (1/4", 3/8", 1/2", 3/4", 1")	4
62	Extra Heavy Close nipples (1/4", 3/8", 1/2", 3/4", 1")	4
63	Brass non sparking hammer	4
64	ALL - N - One Chek-Lok Socket	4
65	Tool – Pipe Extractor Set	4
66	Extra Heavy 3-inch nipples (1/4", 3/8", 1/2", 3/4", 1")	4
67	Extra Heavy Plug (1/4", 3/8", 1/2", 3/4", 1")	4
68	Reducers (1/4' x 3/8", 3/8' x 1/2", 1/2' x 3/4", 3/4' x 1", 1" x 1-1/4", 1-1/4" x 1-1/2", 1-1/2' x 2")	4
69	Tool – POL wrench	4
70	Propane Specialist Response Kit Box # 4	4
71	Tool Tote	4
72	Custom Lexan case divider	4
73	10-foot 1/2" hose with 300 psi gauge, hydrostatic relief and ball valve (1-3/4" Female ACME x 1-3/4" Male ACME)	4
74	Dead Blow Hammer	4
75	12" x 3/8 female flare straight motor fuel x 1-3/4" Male ACME	4
76	12" x 3/8 female flare 90-degree motor fuel x 1-3/4" Male ACME	4
77	12" x Fork Truck Safety Connector 90-degree motor fuel x 1-3/4" Male ACME	4
78	12" x Male POL x Female POL 90-degree	4
79	1-3/4" Female ACME x 1-3/4" Male ACME extension with ball valve	4
80	OLD style Chek-Lok 7572C-14A liquid propane evacuation adapter with schedule 80 pipe extension and 1-3/4" male ACME (designed for underground storage tanks)	4
81	NEW style Chek-Lok 7590U-10 liquid propane evacuation adapter with schedule 80 pipe extension and 1-3/4" Male ACME (designed for underground storage tanks)	4
82	Box #4 foam insert	4
	Full Graphic Set	

Propane Specialist Response Kit Users Guide

Kit Component Location Map

Note: Some kit items are not referenced in this GUIDE because they are not specific valve connectors.

Propane Specialist Response Kit - Box # 1



Propane Specialist Response Kit - Box # 2

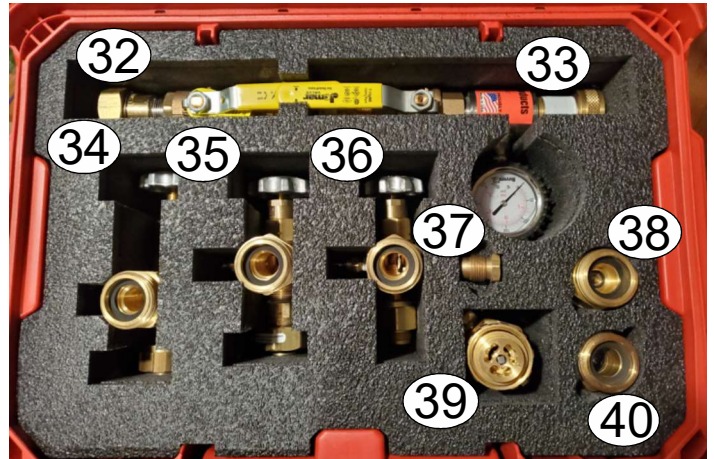

Propane Specialist Response Kit - Box # 3

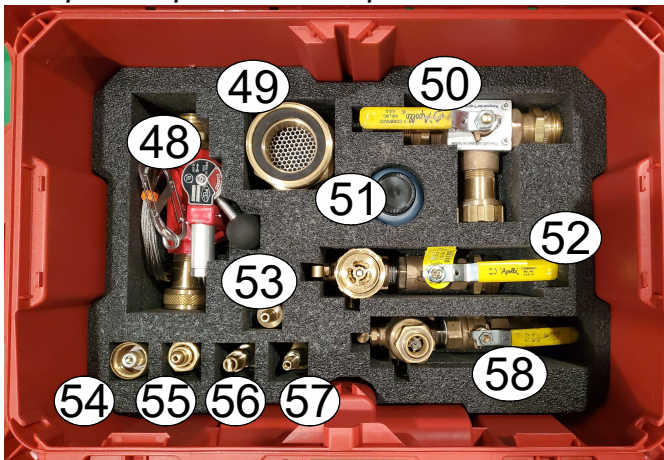

The items in Box #1's Left side storage area and the lift out Tool Totes from Boxes # 3 & 4 have been intentionally omitted because their components are not referenced in this document. However they are all listed on pages 4 & 5 of this guide.

Propane Specialist Response Kit - Box # 4

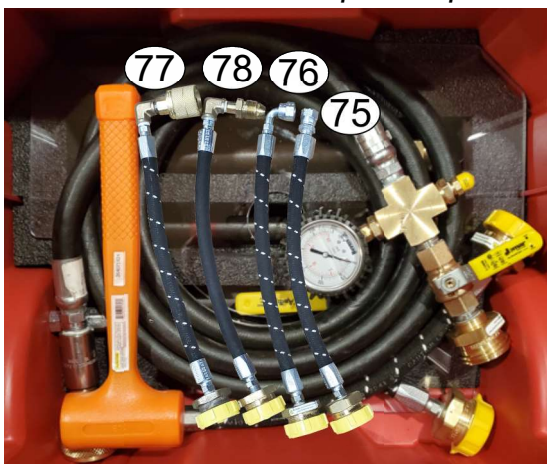

Component Application and Identification Guide

COMMON Residential Tank Connections

Identified tank connection points may only need one of the items identified or multiple pieces to accomplish the task.

<p>Vapor/Fill Valve 1 3/4" Male ACME</p>	<p>Service Valve Vapor (P.O.L.)</p> <p>Vapor Return 1-1/4" Male ACME</p>	<p>OLD Style - Liquid Withdrawal Valve</p>	<p>NEW Style - Liquid Withdrawal Valve</p>
<p>Liquid Volume Gauge 0-100%</p>		<p>Pressure Relief Device</p>	
<p>Box 1 - #1 "or" Box 2 - #34 "or" Box 2 - #39 "or" Box 2 - #38</p>	<p>Box 1 - #6 Box 2 - #37 Box 4 - #78 Box 1 - #4 Vapor Return</p>	<p>Box 2 - #36 "or" Box 3 - #58 "or" Box 4 - #80</p>	<p>Box 2 - #32 "or" Box 2 - #35 "or" Box 3 - #52 "or" Box 4 - #81</p>

Add a control valve assembly

Box 4 - #73

Box 2 - #33



Component Application and Identification Guide

COMMON Underground Tank Connections

Identified tank connection points may only need one of the items identified or multiple pieces to accomplish the task.

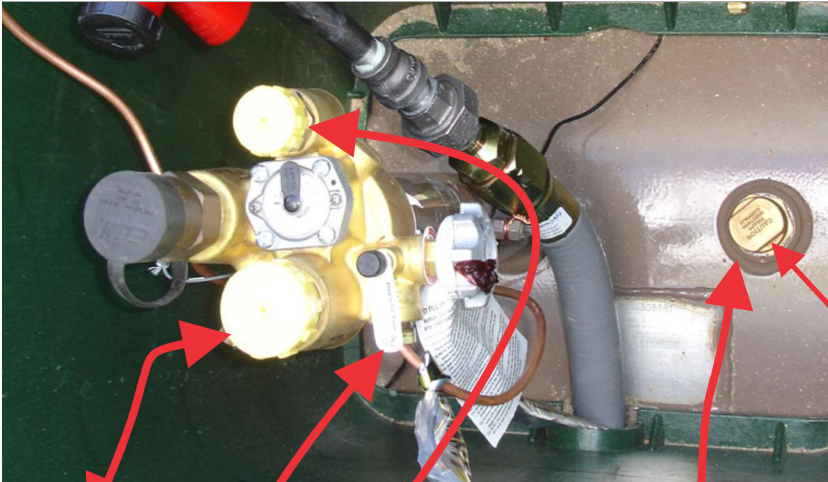

New Style Liquid Withdrawal (35) (81)

Old Style Liquid Withdrawal (36) (80)



Box 2 - #34
"or"



Box 2 - #39
"or"



Box 2 - #38



Box 1 - #4



Box 1 - #6



Box 2 - #37



Box-4 #80



Box-4 #81



Box-4 #79

ALL-N-One Set



Fits 2 Styles of LWD Caps Fits 4 Styles of LWD caps
Propane Liquid Withdrawal Valve Socket Set

Add a control valve assembly



Box 4 - #73



Box 2 - #33



Component Application and Identification Guide

Identified tank connection points may only need one of the items identified or multiple pieces to accomplish the task.

Overfill Protection Device (OPD)

Pressure Relief Device

Service/Vapor Valve Control Handle

POL

1-5/16" Male ACME Thread (QCC Type 1)

80% Bleeder/tube

Box 1 - #5

Box 1 - #6

Box 1 - #5

Box 1 - #6

Box 2 - #37

Box 4 - #78

Vapor Service Valve with POL Connection ONLY

Box 1 - #6

Box 2 - #37

Box 4 - #78

Add a control valve assembly

Box 4 - #73



Box 2 - #33

Component Application and Identification Guide

Motor Fuel Tank Connections

Identified tank connection points may only need one of the items identified or multiple pieces to accomplish the task.

Motor Fuel Connections



Box 1 - #6



Box 2 - #34
"or"



Box 2 - #39
"or"



Box 2 - #38



Box 4 - #75



Box 4 - #76

Box 2 - #37



Box 4 - #78



ForkLift Connections



Box 1 - #9



Box 2 - #34 +
Box 1 - #2
"or"



Box 2 - #39



Add a control valve assembly



Box 4 - #73



Box 2 - #33

Component Application and Identification Guide

Specialty Tank Connections

Identified tank connection points may only need one of the items identified or multiple pieces to accomplish the task.

Camper Low Pressure (regulated) Connections



Box 3 - #56



Box 3 - #57



Box 1 - #6

HIGH Pressure Quick Connection



Box 3 - #53



Box 1 - #6

Cylinder Liquid Withdrawal Connection

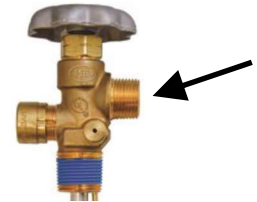

Box 3 - #55



Box 1 - #6

The flexible 90 degree POL hose connector in Box#4 can be used instead of item #6



Box 4 - #78

Lawn Mower Propane Tank Connection - Left Hand Thread

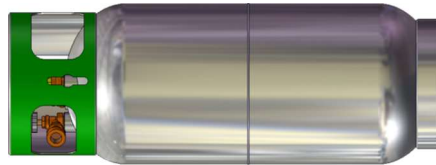

Box 3 - #54



Box 1 - #6

1-Pound Cylinder



Box 1 - #7



Box 1 - #6

Add a control valve assembly



Box 4 - #73



Box 2 - #33



Component Application and Identification Guide

Bulk Plants and DOT MC330/331

Identified tank connection points may only need one of the items identified or multiple pieces to accomplish the task.

Bulk Plants



DOT MC330/331

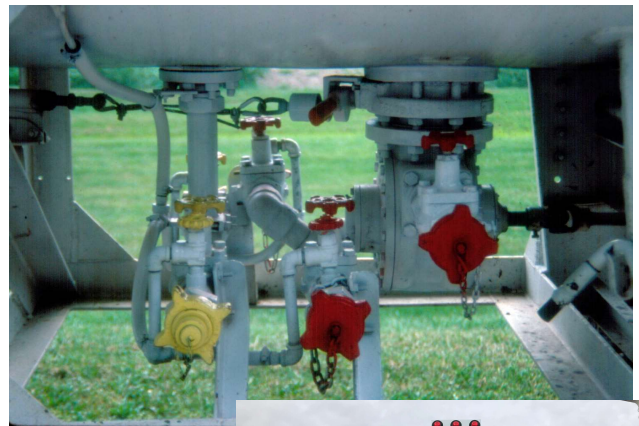

Box 2 - #40



Box 1 - #8



Box 1 - #3



Box 2 - #49

Add a control valve assembly



Box 4 - #73



Box 2 - #33



OPD Valve with QCC Type 1 and POL Connections



Since October 1st 1998 all new 4 to 40 pound cylinders have been required to have an Overfill Protection Device (OPD) installed. The OPD is designed to stop product flow into the cylinder during the filling process in excess of the maximum permitted filling limit or 80% of the tanks capacity. Along with this change came the Federal regulation requiring that propane tanks with an OPD's must be re-certified 12 years from the date of manufacture stamped on the tank. Tanks that have been re-certified must then be re-certified every 5 years. This standard has changed to exclude horizontal tanks.

OPD cylinder valves may have either a CGA (Compressed Gas Association) 791 (ACME threads) or a CGA 810 (push-pull, quick disconnect) connection device.

In addition to the 80% fill limiter, OPD valves contain a Discharge Check Valve. It's purpose is to prevent discharge from the cylinder unless a POL (Prest-O-Lite) or QCC (Quick Closing Coupling) type-1 fitting is connected to the valve. When the connector is properly threaded onto the OPD valve it pushes open the Discharge Check Valve and allows propane to flow through the connector and to the attached appliance.



QCC Type 1 connectors are color coded to indicate the maximum BTU per Hour that each are capable of producing. **BLACK** is the lowest at 100,000 BTU/hour, **GREEN** is next at 200,000 BTU/hour and **RED** is the maximum at 400,000 BTU/hour.

Currently OPD valves with the QCC Type-1 connector are still capable of receiving a male POL, this could change someday. But, for now if you need to flare a larger quantity of propane than the QCC Type-1 is capable of, you may be able to use a full flow POL.

The QCC connector (CGA 791) is a 1-5/16" ACME (right hand thread) which is found on BBQ and other systems with OPD valves.

When purchasing propane equipment such as portable heaters they often are shipped with a POL connector. Don't be confused by the large QCC Type-1 threads.

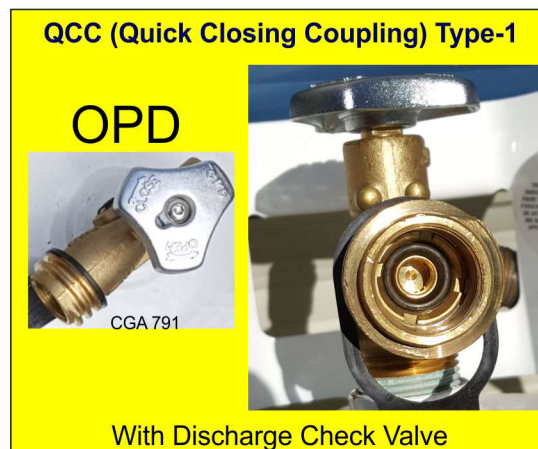
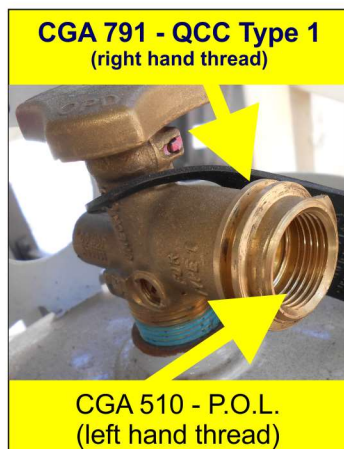







Component Application and Identification Guide

Liquid Withdrawal

Performing liquid withdrawal operations on an OLD style Chek-Lok using the 7572C-14A adapter has always been accompanied by a release of liquid propane until the adapter has been tightened down. The New style adapter (7590U-10) stops the release with the new design and the use of an O-Ring.



 <p>New Style 7590U-10</p> <p>Box 2 - #31, 35 Box 4 - #81</p>	<p>New Style Liquid Withdrawal</p> 	 <p>Old Style Liquid Withdrawal</p>	 <p>Old Style 7572C-14A</p> <p>Box 2 - #36 Box 4 - #80</p>
 <p>Box-2 #35</p> <p>NEW style Liquid Evacuation Valve adapter utilizes an <u>O-ring</u> to seal the valve to the tank unit.</p>	 <p>Box-2 #36</p> <p>This style adapter is used on the Old style Liquid Evacuation Valve and <u>DO NOT seal to the tank unit until it is securely tightened.</u></p>		

New Style Liquid Withdrawal (straight)
Box-2 #32

1-inch Control Valve W/Gauge
Box-2 #33

New Style Liquid Withdrawal
Box-2 #35

Old Style Liquid Withdrawal
Box-2 #36

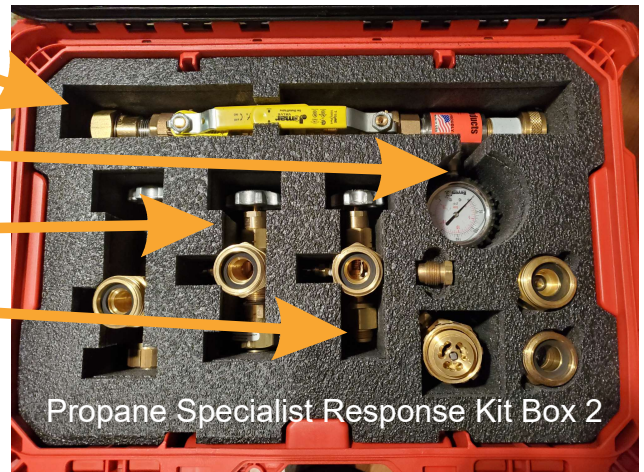

Loosen cap to vent any accumulated LP-Gas from the Liquid Withdrawal Valve. After venting stops, remove the cap. If venting does not stop, retighten the cap and use other approved means to withdraw liquid from the container. **NOTE:** Use a suitable size wrench when removing the cap and adapter from the Chek-Lok. **Do not allow the Chek-Lok to un-thread from the tank during removal.** **When necessary, use a second wrench to secure the Chek-Lok in position.**

Contact Responder Training Enterprises, LLC, for your propane response training and equipment needs. Ron Huffman, respondertraining.rdh@gmail.com www.respondertraining.com or (765) 524-4848

REGO Liquid Withdrawal Adapters

Performing liquid withdrawal operations on an OLD style Chek-Lok using the 7572C-14A adapter has always been accompanied by a release of liquid propane until the adapter has been tightened down. The New style adapter (7590U-10) stops the release with the new design and the use of an O-Ring.



To go a step further the REGO 7580F-20 and 7590U-20 Chek-Lok® adapters eliminate gas flow when installing or removing!

The adapter's operating handle rotates moving the equalizing stem in the Chek-Lok® valve up and down. When the handle is "UP" or in the "CLOSED" position, potential gas flow through Chek-Lok® valve is stopped. Use of the RegO adapter ensures proper connections and opening of the check mechanism.

The **REGO 7580F-20** adapter is specifically designed to eliminate the need for gas to flow from the OLD style ChekLok® when the adapter is installed or removed.

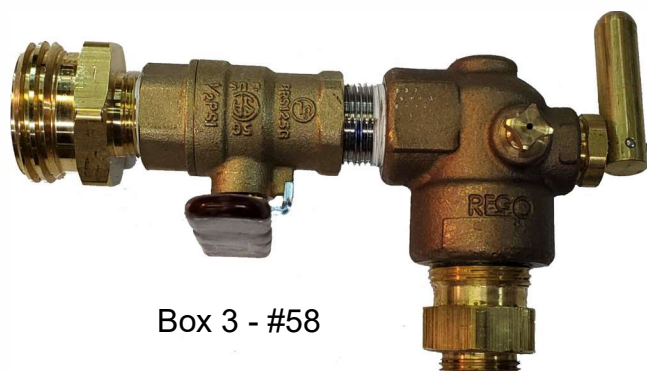

Box 3 - #58

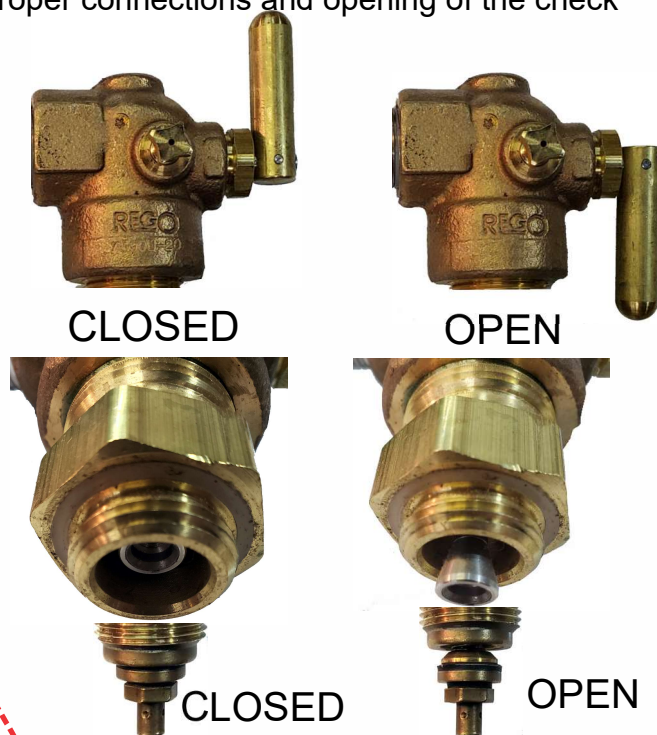

While not as common as the 7590U-10, the **REGO 7590U-20** is also designed specifically to be used with the NEWER style RegO ChekLok® Excess Flow Valves.



Box 3 - #52

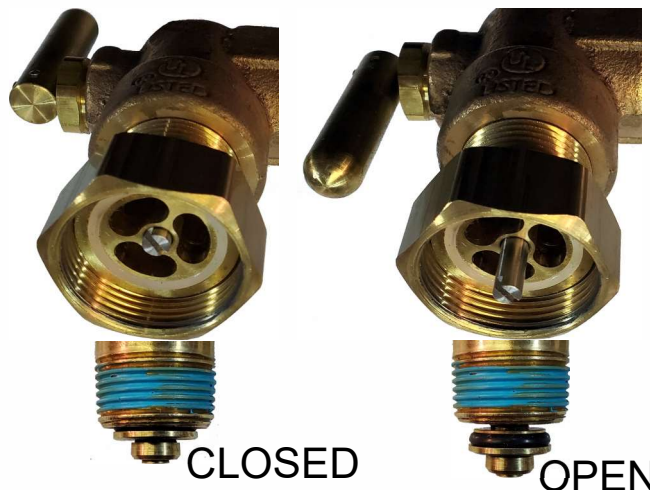

RESPONDERTRAINING.COM

NOTE: Instructions to Open Chek-Lok® (REGO text)

Loosen cap to vent any accumulated LP-Gas from the Chek-Lok. After venting stops, remove the cap. If venting does not stop, retighten the cap and use other approved means to withdraw liquid from the container. **NOTE:** Use a suitable size wrench when removing the cap and adapter from the Chek-Lok. Do not allow the Chek-Lok to un-thread from the tank during removal. When necessary, use a second wrench to secure the Chek-Lok in position.

Contact Responder Training Enterprises, LLC, for your propane response training and equipment needs. Ron Huffman, respondertraining.rdh@gmail.com www.respondertraining.com or (765) 524-4848

Propane Fill Valves and Unloading Adapters



RESPONDERTRAINING.COM
 respondertraining.rdh@gmail.com
 Training by responders, for responders

On most tanks and cylinders without a dedicated large bore vapor connection such as a Mc331, a 1-3/4" ACME connection that is commonly used as a filler valve would be a good choice for vapor flaring operations.

Note: Unloading adapters such as the REGO 3119a and the REGO 3121 are not valves. They are designed to open the tank connection only. A separate control valve assembly should be installed inline in case the tank valve does not reseal.

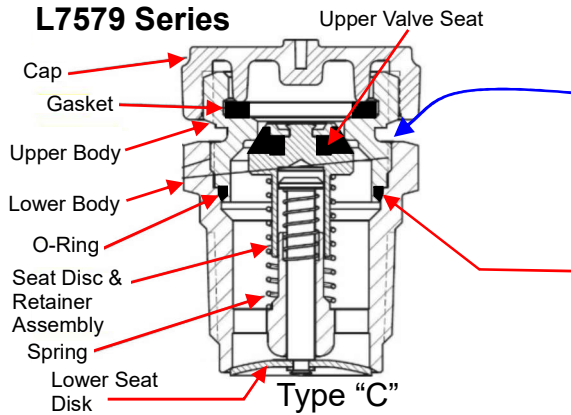

Upper O-Ring leak on underground tank

SPECIAL NOTE: LEFT HAND thread



Box 2 - #39 Box 2 - #34



6579 Series valves include a swing-away check



1 3/4" ACME Gasket

Back Check

Type "C"

Seat Disk

SPECIAL NOTE: LEFT HAND thread
 Screw Down to OPEN - Up to CLOSE



Rego 3119a
 Box 2 - #39



Rego 3121
 Box 2 - #34



1 3/4" Female ACME (In only)



1 3/4" Female ACME (In and Out)
 Should be used with a control valve. PSRK Box 1 - #1

LIQUID LOADING-UNLOADING ADAPTOR (In and Out)

SPECIAL NOTE: when using the Rego 3121 or Marshal Excelsior 450 adapter verify that the valve stem is completely retracted (UP) prior to connecting it to the Double-Check Filler Valve. Failure to do so may cause an unwanted product release.

Screw Down to OPEN - Up to CLOSE

WARNING: In many makes of valves, the valve opening distance may be less than the plunger travel of the adapter. Do not force the handwheel if it appears that the Filler Valve is wide open (screwed down).

Basic propane metering system components

One of my jobs while employed in the propane service industry was repairing propane metering systems. This included systems from Veeder Root, Liquid Controls, Neptune, Mid-Com and others. I thought a description of a few of the most common components could be helpful.

Generally, a system is designed with a register head (a) (part that displays the gallons pumped, it could also be inside the cab) sits atop of the measuring chamber (b).

The measuring chamber is supplied liquid propane through a vapor eliminator (c). The strainer (d) is typically made from stainless steel and or brass and is inside of the vapor eliminator, it's designed to catch debris in the supply before it gets to the measuring chamber.

Propane is fed into the middle of the strainer (usually from the back of the assembly). The vapor eliminator has a float assembly connected to an internal control valve that closes if the liquid gets high enough. The vapor line is connected to the differential valve (e) (flat round component with a diaphragm) via hose or tube (f). The vapor line is also connected back to the vapor system in the tank. This will need to be closed to stop vapor from leaking if the system is broken open in an accident.

Units typically have an temperature compensator (g) that is used to calibrate the system to 60 degrees F (in the U.S.) and adjust the registers reading based off of product temperature and a thermometer well (h) used during calibration.



Ron Huffman

Owner, Responder Training Enterprises, LLC.

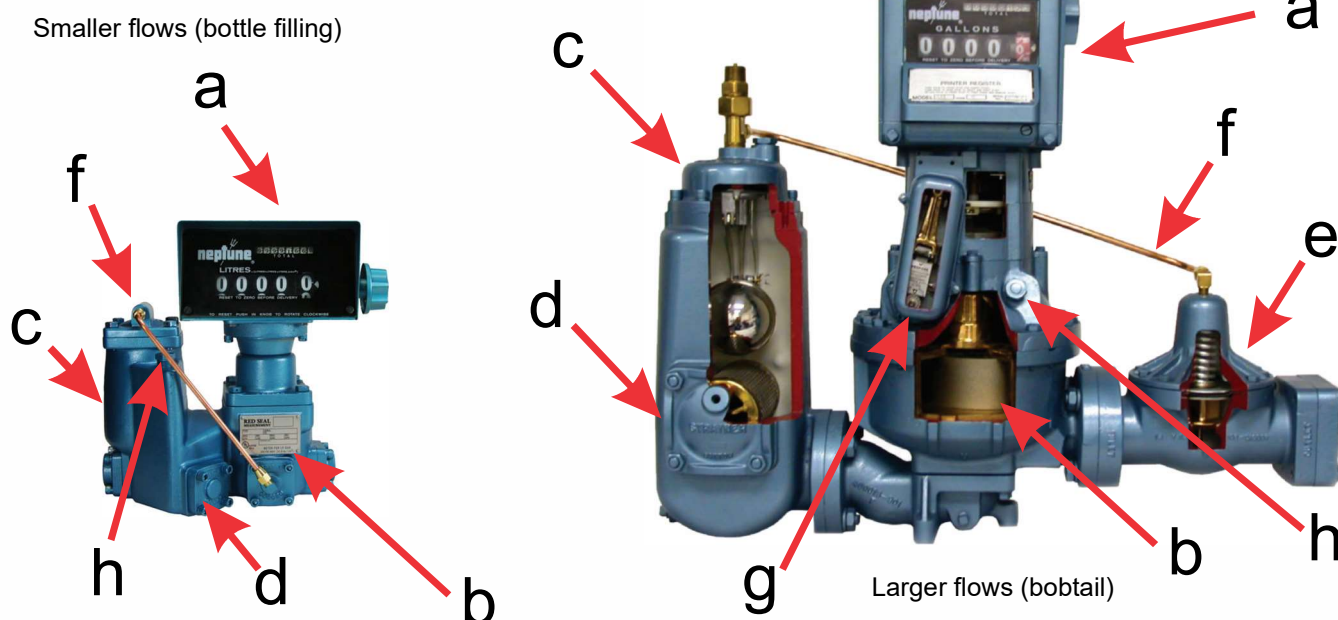

Propane Fact Sheet

DOT GUIDEBOOK
GUIDE # 115, 366, 374



www.ResponderTraining.com

Chemical Name: Propane
Chemical Family: Hydrocarbon
Chemical Formula: C₃H₈

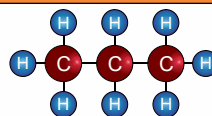

CAS Registry No.: 74-98-6

IDLH: 2200 ppm (based on 10% LEL)

LEL: 2.15 (2) UEL: 9.6 (10)

Vapor Density: 1.5

Specific Gravity: 0.5

Vapor Pressure: 95 psig @ 60 Deg. F

Boiling Point: -44 Deg. F

Freeze Point -306

Evaporation Rate: Gas at normal ambient temperatures

Flash Point: -156 Deg. F

Ignition Temp.: 900 - 1100 Deg. F

Weight: 4.24 Lbs. per gallon @ 60 Deg. F

Expansion Ratio: 270 - 1

Solubility: Not soluble in water

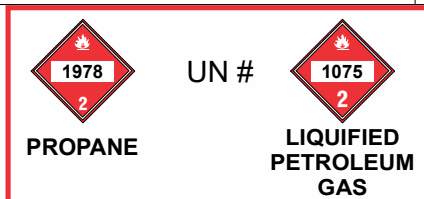

NFPA -704

FIRE - Red

HEALTH
- Blue

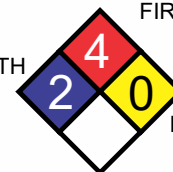

REACTIVITY
- Yellow

SPECIAL HAZARDS - White

Color: Colorless

Odor: Odorless, ALSO SEE BELOW

Percent Volatile by Volume (%): 100

Stability: Stable

Hazardous Polymerization: Will not occur

Decomposition Products: CO, CO₂

OSHA PEL: 1000 ppm

ACGIH TLV: 1000 ppm

STORAGE VESSALS

Propane and other Liquefied Petroleum Gases (LPG) are shipped in container sizes from less than 1 ounce, to over 34,000 gallons (railcar). Cigarette lighters, hand held torches, spray cans, semi trailers and rail cars can all be used as a vessel to hold propane and other LPG's.

Normally small cylinders (less than 4 lbs.) are used to supply propane vapor and do not have a dip tube (80% liquid tube). If a cylinder that was designed to supply vapor only is inverted, liquid will be expelled from the vapor opening. If this happens, place the cylinder in an upright position to convert the leak back to vapor.

20 lb. or gas grill type cylinders should never be stored in an inverted position, unless completely void of liquid.

NEVER use the OPD valve as the fill stop.

Pre-Plan your local area and know what's being transported, stored and how!

EMERGENCY RESPONSE

Warning : Danger! Compressed Flammable gas. Simple asphyxiate: death possible in higher concentrations (IDLH 2200 ppm). Contact with liquid causes cryogenic type burns, can be extreme, similar to frost bite.

If responding to a tank on fire: YOUR FIRST DECISION must be whether to apply water or evacuate the area. If an attack is made, apply water to the point of flame contact first and continuously then to other tank surfaces to cool the tank. Manage vapor leaks as needed. If possible use un-maned or remote nozzles. After the fire has been extinguished continue to apply water to the tank surface until the tank is cool. If possible you should NOT extinguish a flammable gas fire with-out shutting off the flow of gas first unless the flame is impinging on the vapor space. If this happens continually disperse product vapors until the hazard is removed.

If responding to a potential odor/leak: Arrive with your meter ready. Calibrated and warmed up, Wear all of you PPE, test LOW medium and high isn accordance with your departments SOP's and SOG's.

Liquid leaks may be able to be converted to a water leak using water injection.

PPE

***Respiratory:** SCBA for gas unknown concentrations and concentrations above occupational exposure limits and firefighting.

***Hands:** Use cold-impervious, insulating gloves where contact with liquid may occur that will not freeze to objects.

***Eyes:** Possibility of liquid contact, wear splash-proof safety glasses and face shield.

***Skin and Body:** Where contact with liquid may occur, wear appropriate cold insulating protective clothing and face shield (SCBA). Structural PPE required for firefighting.

Extinguishing Media: Shut off source, Water Injection, Water spray, Class A-B-C or BC extinguisher.

Product vapors will gather in low areas, check all low areas for gas vapor accumulations (ditches, sewers, river beds and structure), disperse product vapors with water fog or forced air.

CAUTION: Flammability limits (i.e., explosion hazard) should be considered when assessing the need to expose personnel to concentrations requiring respiratory protection.

Flaring Site Plan (training/incident)

Propane Response - 101 to Advanced Tactics Class practical site plan for Liquid Propane Flaring Operations using the **1-inch Responder Flare (AKA The Dragon Slayer)**.

Smaller flares with reduced flows or propane systems that can not supply full 1-inch liquid flows will not require the same size spacing.

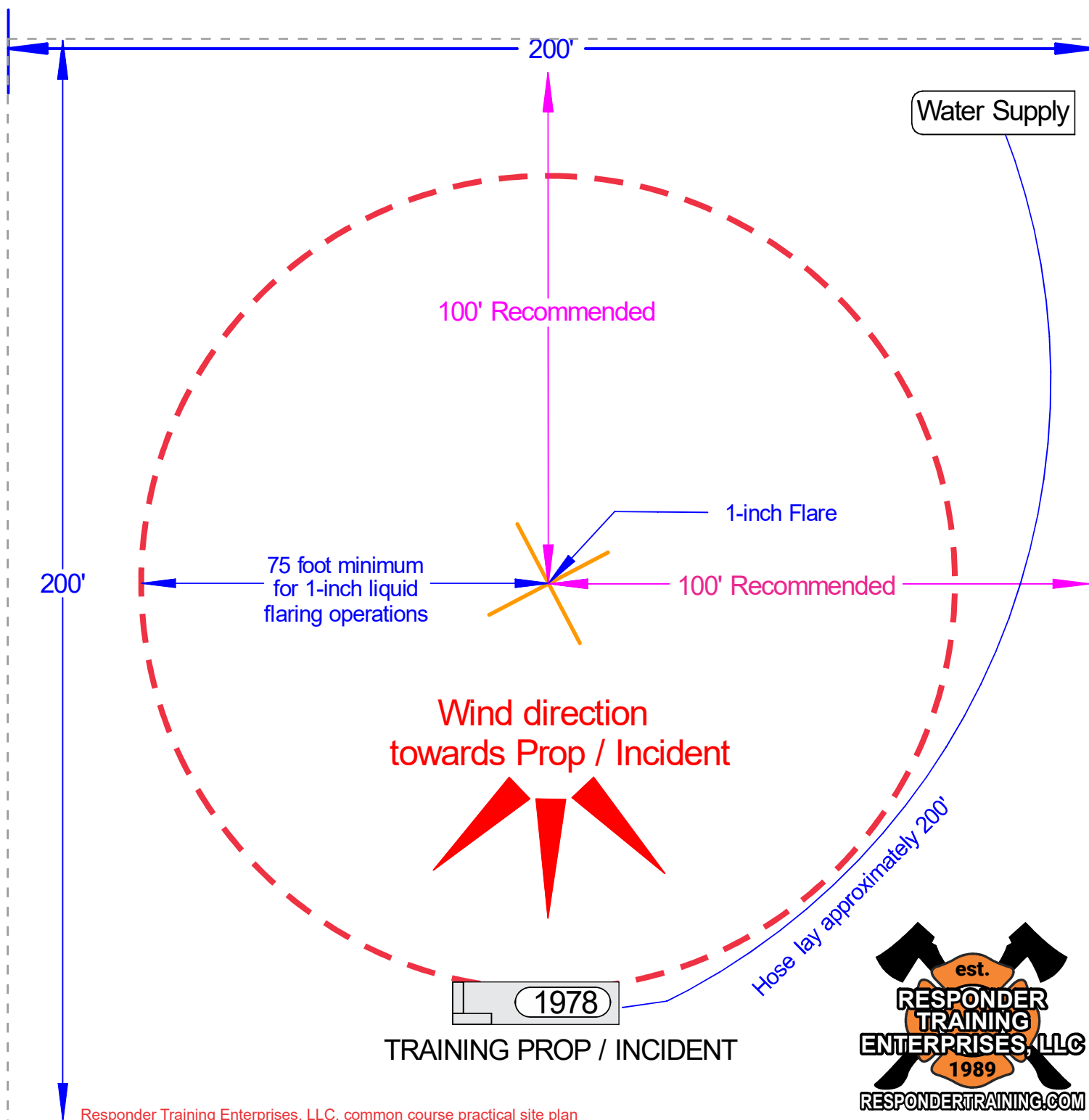

These are the "minimum" distances *commonly used* by Responder Training Enterprises, LLC. based on the radiated heat produced while burning LIQUID propane using our 1-inch flare.

Responder Training Enterprises, LLC
WWW.RESPONDERTRAINING.COM



TRAINING and EQUIPMENT
FOR RESPONDERS
BY
RESPONDERS